

# Framed Quilt (Q-002)

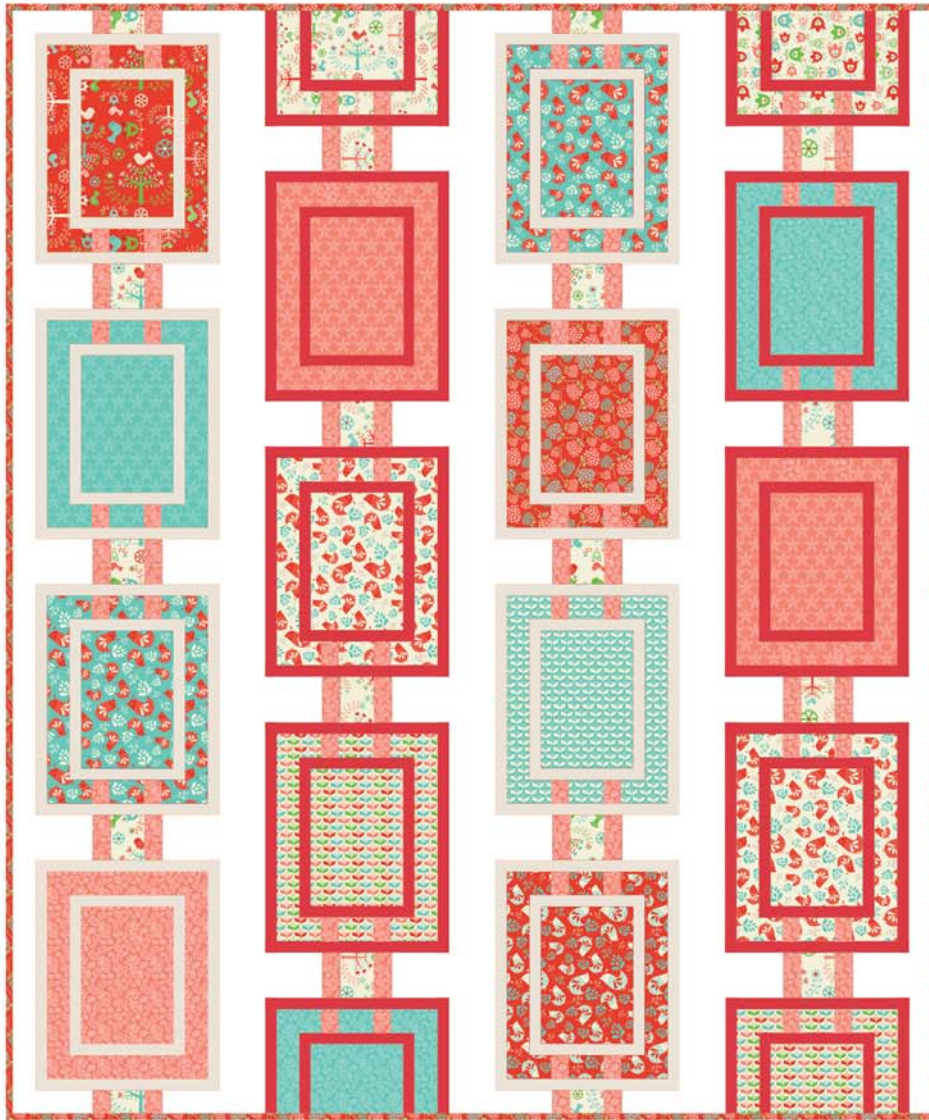

## Fabric requirements



Fabric A  
6141101 #2  
Fat Quarter



Fabric B  
6141102 #1  
Fat Quarter



Fabric C  
6141102 #3  
Fat Quarter



Fabric D  
6141102 #3  
Fat Quarter



Fabric E  
6141101 #1  
Fat Quarter



Fabric F  
6141106 #1  
Fat Quarter



Fabric G  
6141106 #2  
Fat Quarter



Fabric H  
6141102 #1  
Fat Quarter



Fabric I  
6141106 #1  
5/8 yard



Fabric J  
6141104 #2  
Fat Quarter



Fabric K  
6141102 #2  
Fat Quarter



Fabric L  
6141107 #2  
Fat Quarter



Fabric M  
6141106 #2  
Fat Quarter



Fabric N  
6141105 #1  
Fat Quarter



Fabric O  
6141107 #1  
Fat Quarter



Fabric P  
6141105 #2  
Fat Quarter



Fabric Q  
6141105 #1  
Fat Quarter



Fabric R  
6141107 #1  
Fat Quarter



Suggested Backing  
6141103 #2  
5-2/3 yards



Fabric S  
6141103 #1  
Fat Quarter



Fabric T  
6141104 #2  
2/3 Yard  
(Binding)



Fabric U  
6141101 #1  
1/3 Yard



Blog, Facebook, Twitter @CamelotFabrics  
Pinterest, YouTube & Instagram @Camelot\_Fabrics  
camelotfabrics.com • camelotfabricsblog.com  
Toll-Free: 1-800-361-4120 • 514-382-2400  
info@camelotfabrics.com • www.camelotfabrics.com

Solids:  
Fabric V: 214-0001 White 2-1/8 yards  
Fabric W: 214-0040 Ruby 1-1/8 yard  
Fabric X: 214-0003 Natural 1-1/8 yards

Finished Quilt Size: 80" x 96"

## OTHER TOOLS & SUPPLIES

- Rotary cutter & mat
- Sewing machine & coordinating thread
- Iron & pressing surface
- Pencil
- 3 yards extra-wide quilt batting (at least 86" wide)

## NOTES

- Please wash, dry & iron your fabric before beginning, and trim selvages.
- For best results, read all directions before beginning.
- Use a 1/4" seam allowance for all sewing.
- WOF = width of fabric.

## Cutting

Focus Prints for first and third columns

- Fabrics A, C, D, F, J, K, L, P:

From each fat quarter, cut the following as shown on the diagram:

- 4 - 2-1/2" x 4-1/2" rectangles (a)
- 2 - 2-1/2" x 3-1/2" rectangles (b)
- 2 - 2-1/2" x 14-1/2" rectangles (c)
- 1 - 8-1/2" x 12-1/2" rectangle (d)
- 1 - 6-1/2" x 8 rectangle (e) – set aside for backing

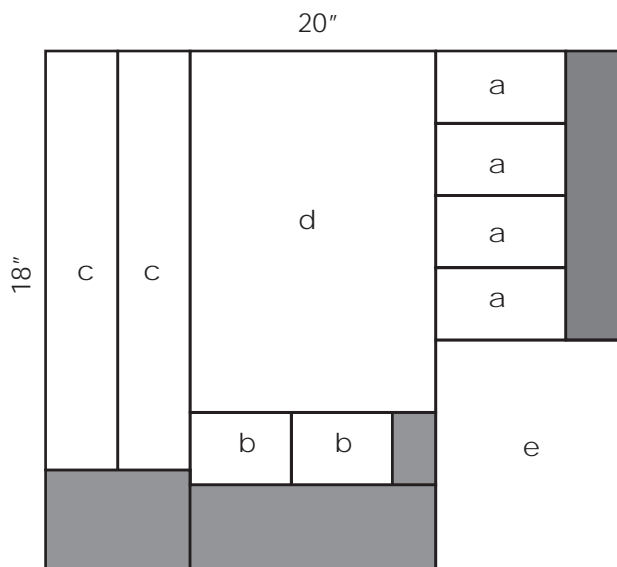

Focus Prints for 2nd and 4th columns

- Fabrics B, E, G, H, M, N, O, Q, R, X:

From Fabrics B, G, H, N, Q & R (used in Full Blocks), cut the following as shown on the diagram above:

- 4 - 2-1/2" x 4-1/2" rectangles (a)
- 2 - 2-1/2" x 3-1/2" rectangles (b)
- 2 - 2-1/2" x 14-1/2" rectangles (c)
- 1 - 8-1/2" x 12-1/2" rectangle (d)
- 1 - 6-1/2" x 8 rectangle (e) – set aside for backing

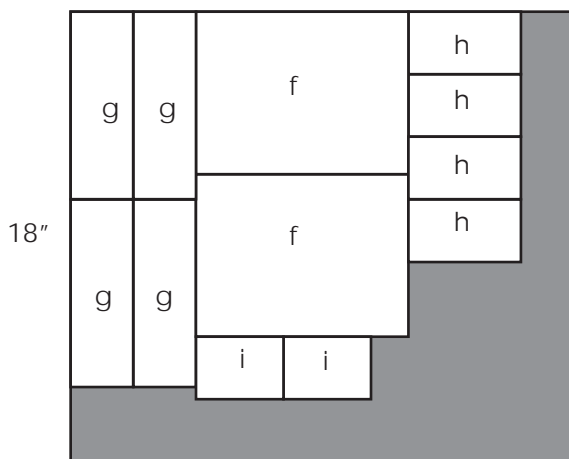

From Fabrics E, M, O & S (used in half blocks), cut the following as shown in the diagram at left:

- 2 - 8-1/2" x 6-1/2" rectangle (f)
- 4 - 2-1/2" x 7-1/2" rectangles (g)
- 4 - 4-1/2" x 2-1/2" rectangles (h)
- 2 - 3-1/2" x 2-1/2" rectangle (i)

Fabric V (background):

Cut 4 – 5-1/2" x WOF strips.

Sub-cut: 28 – 5-1/2 x 4-1/2" rectangles.  
and 8 – 5-1/2" x 2-1/2" rectangles for sashing blocks.

Cut 8 – 4-1/2" x WOF strips for sashing strips.

Cut 5 – 2-1/2" x WOF strips for sashing strips.

Fabric W:

Cut 24 – 1-1/2" x WOF strips.

Sub-cut: 12 – 1-1/2" x 18-1/2" rectangles,  
16 – 1-1/2" x 16-1/2" rectangles,  
12 – 1-1/2" x 12-1/2" rectangles,  
16 – 1-1/2" x 10-1/2" rectangles,  
8 – 1-1/2" x 9-1/2" rectangles  
and 8 – 1-1/2" x 6-1/2" rectangles.

Fabric X:

Cut 26 – 1-1/2" x WOF strips.

Sub-cut: 16 – 1-1/2" x 18-1/2" rectangles,  
16 – 1-1/2" x 16-1/2" rectangles,  
16 – 1-1/2" x 12-1/2" rectangles,  
and 16 – 1-1/2 x 10-1/2 rectangles.

Fabric U:

Cut 2 – 4-1/2" x WOF strips.

Sub-cut: 14 – 3-1/2" x 4-1/2" rectangles.

Sub-cut remaining strip to 2 –1/2" and cut 4 – 3-1/2" x 2-1/2" rectangles.

Fabric I:

Cut 2 – 4-1/2" x WOF strips.

Sub-cut: 28 – 2" x 4-1/2" rectangles for sashing blocks

Cut 4 – 2-1/2" x WOF strips.

Sub-cut 72 – 2" x 2-1/2" rectangles for blocks and sashing blocks.

Fabric T:

Cut 9 – 2-1/4" strips x WOF for binding.



# PIECING

## Full Blocks

Each full block is made using one focus fabric, an accent fabric (either Fabric X or Fabric W) and 2" x 2 1/2" Fabric I rectangles. Follow the instructions below to make 1 block from each combination shown in the chart.

Total: 14 Full Blocks

ACCENT	FOCUS
Fabric X	Fabric A
Fabric X	Fabric P
Fabric X	Fabric C
Fabric X	Fabric F
Fabric X	Fabric D
Fabric X	Fabric J
Fabric X	Fabric L
Fabric X	Fabric K
Fabric W	Fabric N
Fabric W	Fabric H
Fabric W	Fabric R
Fabric W	Fabric G
Fabric W	Fabric Q
Fabric W	Fabric B

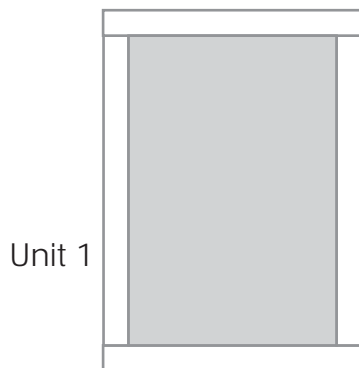
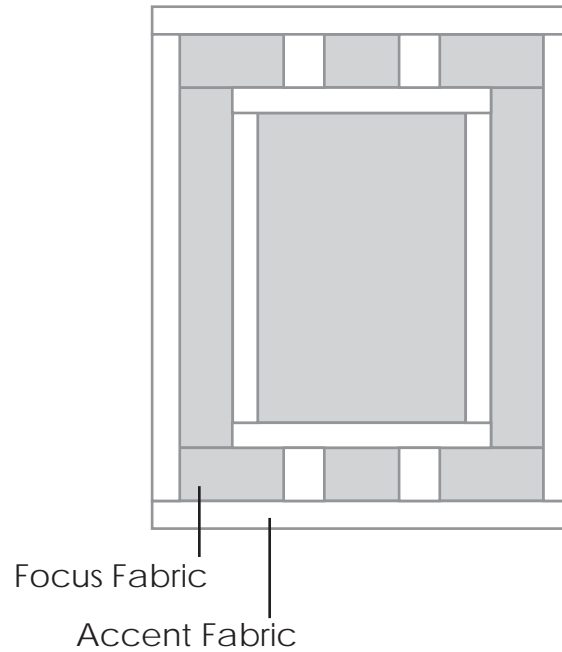

Sew a 1-1/2" x 12-1/2" accent rectangle to the sides of a 8-1/2" x 12-1/2" focus rectangle. Sew a 1-1/2" x 10-1/2" accent rectangle to the top and bottom of the focus rectangle to make Unit 1.

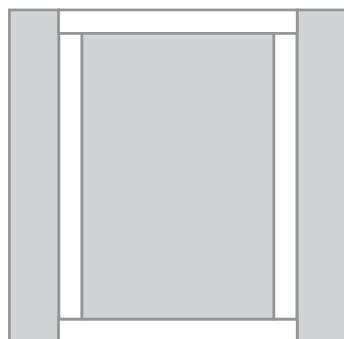

Sew a 2-1/2" x 14-1/2" focus rectangle to each side of Unit 1.

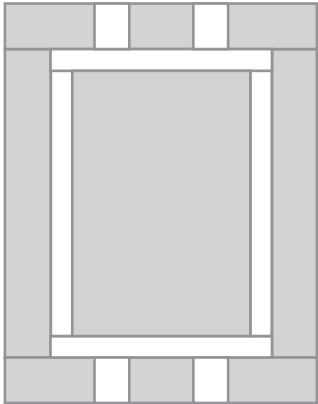

Sew 2 – 2-1/2" x 4-1/2" and 1 – 2-1/2" x 3-1/2" focus rectangles together with 2 – 2" x 2-1/2" Fabric I rectangles as shown. Make 2 of these units and sew them to the top & bottom of Unit 1.

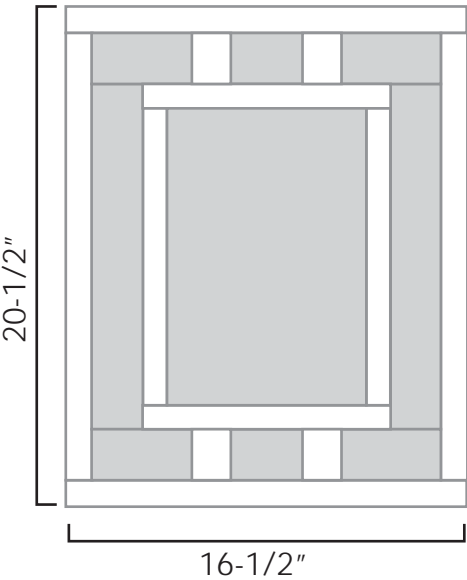

Sew a 1-1/2" x 18-1/2" accent rectangle to the sides of Unit 1. Sew a 1-1/2" x 16-1/2" accent rectangle to the top and bottom of Unit 1. Unfinished Full Block size is 16-1/2" x 20-1/2" .

Half Blocks

Each half block is made using one focus fabric, accent Fabric W and 2" x 2-1/2" Fabric I rectangles. Follow the instructions below to make 1 block from each of the combinations shown in the chart.

Total: 4 Half Blocks.

ACCENT	FOCUS
Fabric W	Fabric E
Fabric W	Fabric M
Fabric W	Fabric S
Fabric W	Fabric O



NOTE: Since prints are unidirectional, the blocks should be oriented as shown:

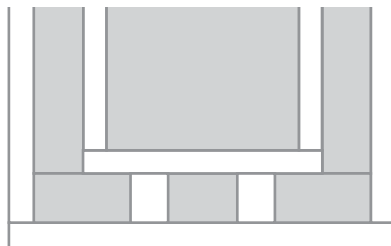

Focus Fabrics E & S

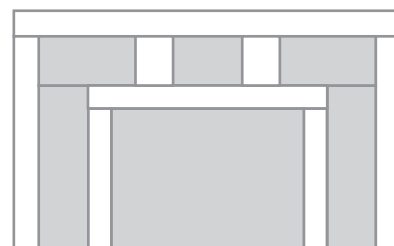

Focus Fabrics M & O



Unit 2

Sew a 1-1/2" x 6-1/2" accent rectangle to the sides of a 6-1/2" x 8-1/2" focus rectangle. Sew a 1-1/2" x 10-1/2" accent rectangle to the bottom of the focus rectangle to make Unit 2.



Sew a 2-1/2" x 7-1/2" focus rectangle to each side of Unit 2.

Sew 2 – 2-1/2" x 4-1/2" and 1 – 2-1/2" x 3-1/2" focus rectangles together with 2 – 2" x 2-1/2" Fabric W rectangles as shown and sew them to the bottom of Unit 2.



Sew a 1-1/2" x 9-1/2" accent rectangle to the sides of Unit 2. Sew a 1-1/2" x 16-1/2" accent rectangle to the bottom of Unit 2. Unfinished Half Block size is 16-1/2" x 10-1/2".

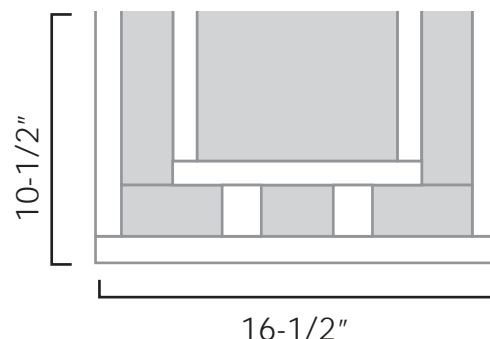

## Sashing Blocks & Strips

Sew 2 – 5-1/2" x 4-1/2" Fabric V rectangles, 2 – 2" x 4-1/2" Fabric I rectangles and a 3-1/2" x 4-1/2" Fabric U rectangle together as shown to make Unit 3. These units will be inserted between blocks (see cover page). Make 14.

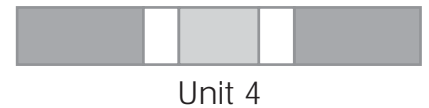
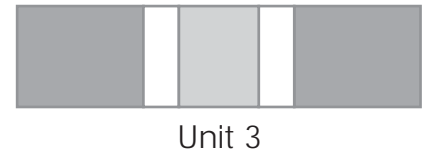

Sew 2 – 5-1/2" x 2-1/2" Fabric V rectangles, 2 – 2" x 2-1/2" Fabric I rectangles and a 3-1/2" x 2-1/2" Fabric U rectangle together as shown to make Unit 4. These units will be inserted between Full Blocks and the top & bottom edges of the quilt (see cover page). Make 4.

## ASSEMBLY

- Arrange full blocks, half blocks and Units 3 and 4 in columns as shown on the front page of the tutorial. Sew the columns of blocks and units together.
- Sew the short ends of 4-1/2" Fabric V strips together. Cut 3 sashing strips to 4-1/2" x 96-1/2". Sew a sashing strip between the columns of blocks.
- Sew the short ends of 2-1/2" Fabric V strips together. Cut 2 sashing strips to 2-1/2" x 96-1/2". Sew a sashing strip to each outer side.

## PIECING THE BACK

- Cut Backing fabric into two equal lengths (approx. 102").
- Randomly sew 14 focus rectangles (set aside for backing) along the short edges. Trim the length to match the backing fabric length.
- Sew this pieced section between two backing pieces for a fun back!

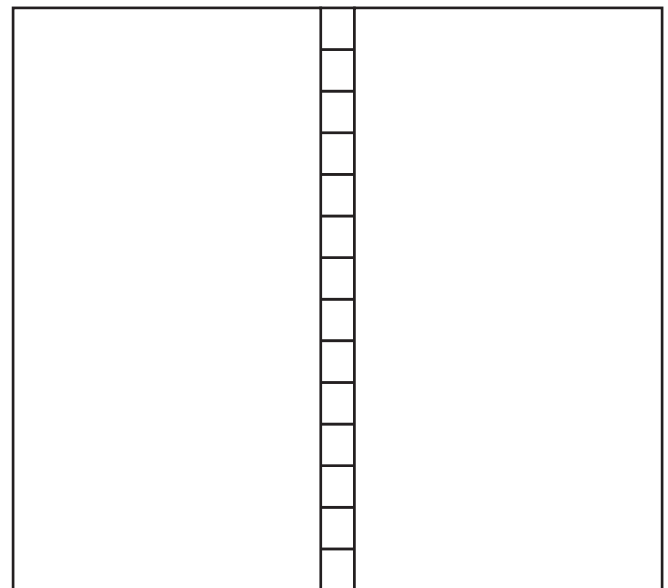

- Layer quilt top with batting and backing. Baste and quilt as desired, and bind with 2-1/4" Fabric T strips.